



INTEGRATED TECHNICAL EDUCATION CLUSTER
AT ALAMEERIA

E-626-A

**Data Communication and Industrial
Networks (DC-IN)**

Lecture #1

Fundamentals of Data
Communications

Instructor:

Dr. Ahmad El-Banna



Agenda



Course Objectives

Course Information

Fundamentals of data communications

Intro. to Layered Communication protocols

Course Aim & Outcomes

➤ **Course Aim:**

- ***Give the learners the knowledge and skills needed to install, test and configure data communication networks used in industrial networks for instrumentation and control.***

➤ **Course Outcomes:**

- ***Determine and analyze the fundamentals of communications.***
- ***Determine and analyze the principles of selecting and installing telecommunications systems.***
- ***Make “best practice” decisions on the best and most cost effective access options for an industrial network.***
- ***Identify, prevent and troubleshoot industrial communications problems.***
- ***Install and configure a simple Ethernet network.***

Course Information

Instructor:	Dr. Ahmad El-Banna http://bu.edu.eg/staff/ahmad.elbanna Office: Room #305 Email: ahmad.elbanna@feng.bu.edu.eg ahmad.elbanna@ejust.edu.eg
Lectures:	Sunday, 12:30 -14:15
Office Hours:	Sunday (14:15~15:30)
T.A.:	Eng.
Texts/Notes:	<ul style="list-style-type: none">W. Stallings, Data and Computer Communications, 8th edition, 2007.
Assignments	<ul style="list-style-type: none">Assignment #1 (P1:P4), 7th week.Assignment #2 (P5:P10), 14th week.

Lectures List

- **Weeks 1:3**
 - *Determine and analyze the fundamentals of communications.*
- **Weeks 4:6**
 - *Determine and analyze the principles of selecting and installing telecommunications systems.*
- **Weeks 7:9**
 - *Make “best practice” decisions on the best and most cost effective access options for an industrial network.*
- **Weeks 10:11**
 - *Identify, prevent and troubleshoot industrial communications problems.*
- **Weeks 12:14**
 - *Install and configure a simple Ethernet network.*
- **Week 15**
 - *Course close and feedback*

FUNDAMENTALS OF DATA COMMUNICATIONS



(6)

DC-IN, Lec#1 , Spring 2015

© Ahmad El-Banna

Data & Communication meanings

- Data, refers to a collection of numbers, characters and is a relative term.
- Data is collected and analyzed to create information suitable for making decisions.
- Communication is the activity of exchanging information and meaning across space and time using various technical or natural means, whichever is available or preferred.
- Communication requires a sender, a message, a medium and a recipient.
- Although the receiver does not have to be present or aware of the sender's intent to communicate at the time of communication.
- Thus, communication can occur across vast distances in time and space.

Data Communication Trends

Three different forces have driven the architecture and evolution of data communications and networking facilities:

- Traffic growth,
- Development of new Services
- Advances in technology.

Speed (kbps)	9.6	14.4	28	64	144	384	2000
Transaction processing	Good	Good	Good	Good	Good	Good	Good
Messaging/text apps	Good	Good	Good	Good	Good	Good	Good
Voice	Good	Good	Good	Good	Good	Good	Good
Location services	Adequate	Good	Good	Good	Good	Good	Good
Still image transfers	Poor	Adequate	Adequate	Good	Good	Good	Good
Internet/VPN access	Poor	Poor	Adequate	Good	Good	Good	Good
Database access	Poor	Poor	Adequate	Good	Good	Good	Good
Enhanced Web surfing	Poor	Poor	Adequate	Adequate	Good	Good	Good
Low-quality video	Poor	Poor	Adequate	Adequate	Good	Good	Good
Hifi audio	Poor	Poor	Adequate	Adequate	Good	Good	Good
Large file transfer	Poor	Poor	Poor	Adequate	Good	Good	Good
Moderate video	Poor	Poor	Poor	Adequate	Adequate	Good	Good
Interactive entertainment	Poor	Poor	Poor	Poor	Adequate	Adequate	Good
High-quality video	Poor	Poor	Poor	Poor	Poor	Adequate	Good

VPN: virtual private network

Performance:



Poor

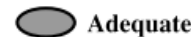

Adequate



Good

Services versus Throughput Rates

A Communications Model

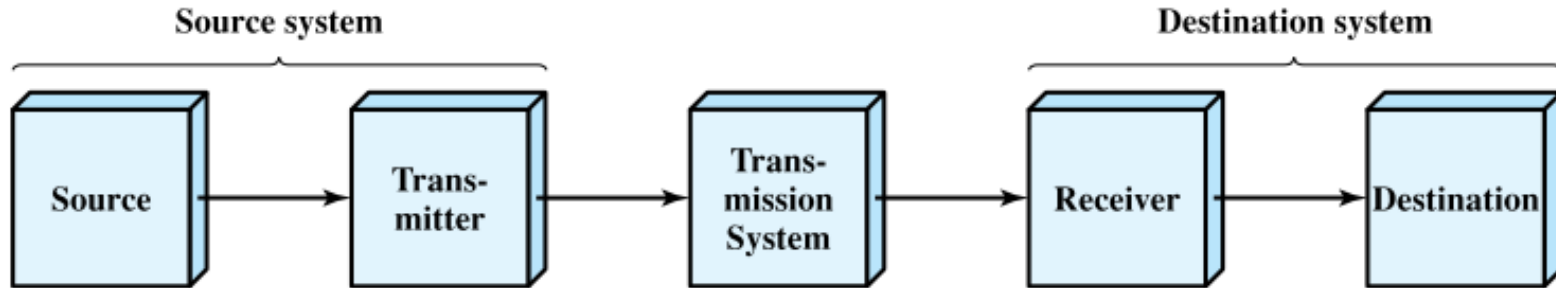

(a) General block diagram



(b) Example

Key Elements of the Communications model

- **Source:** This device generates the data to be transmitted; examples are telephones and personal computers.
- **Transmitter:** transforms and encodes the information in such a way as to produce electro magnetic signals that can be transmitted across some sort of transmission system.
- **Transmission system:** This can be a single transmission line or a complex network connecting source and destination.
- **Receiver:** The receiver accepts the signal from the transmission system and converts it into a form that can be handled by the destination device.
- **Destination:** Takes the incoming data from the receiver.

Communications Tasks

Transmission system utilization	Addressing
Interfacing	Routing
Signal generation	Recovery
Synchronization	Message formatting
Exchange management	Security
Error detection and correction	Network management
Flow control	

Simplified Data Communications Model

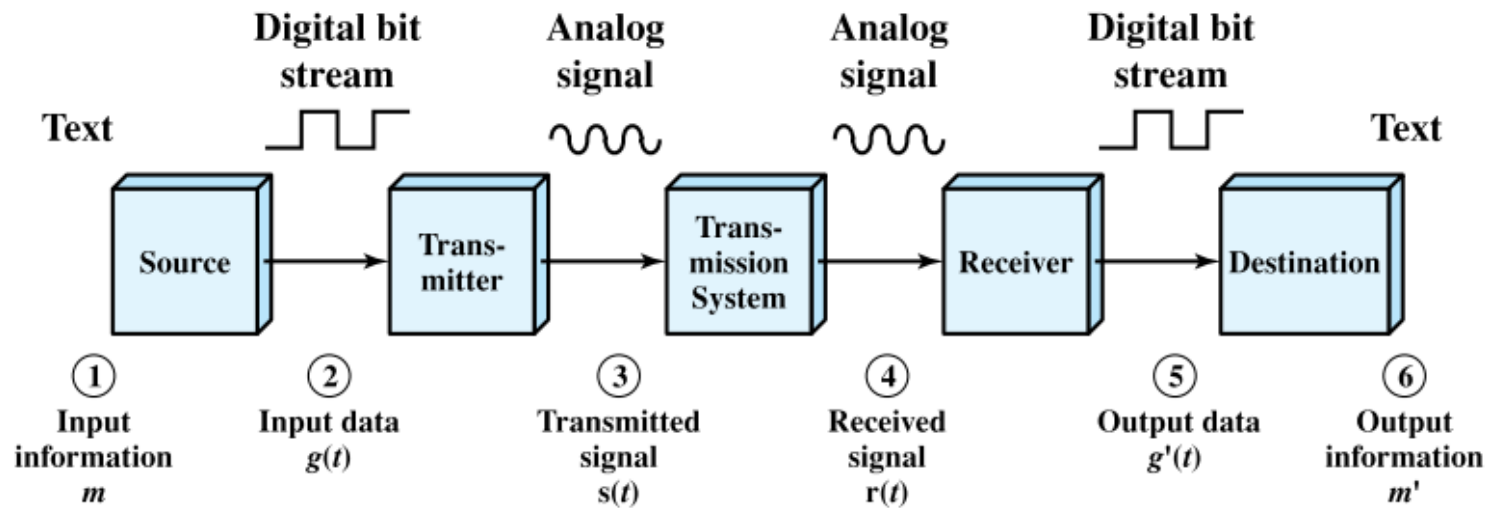

Data Communications Aspects

- The Transmission of Information:
 - Transmission media: twisted-pair, coaxial cables, fiber optic, wireless,..
 - Antennas: dipole, yagi-uda, dish (parabolic) , microstrip,..
 - ...
- Communication Techniques:
 - Encoding : source, channel
 - Modulation: Analog, Digital
 - ..
- Transmission efficiency:
 - Capacity issue: Multiplexing, compression,..
 - Data rate
 - ...

Networks

- LAN - Local Area Network
 - single building or cluster of buildings
 - ethernet, token ring, star, wireless
- WAN - Wide Area Network
 - city-to-city, country-to-country
 - telephone, ISDN, ATM, etc.
- Wireless Network
 - radio, microwave, satellite

Internet

- Internet evolved from ARPANET
- Developed to solve the dilemma of communicating across arbitrary, multiple, packet-switched network
- TCP/IP provides the foundation

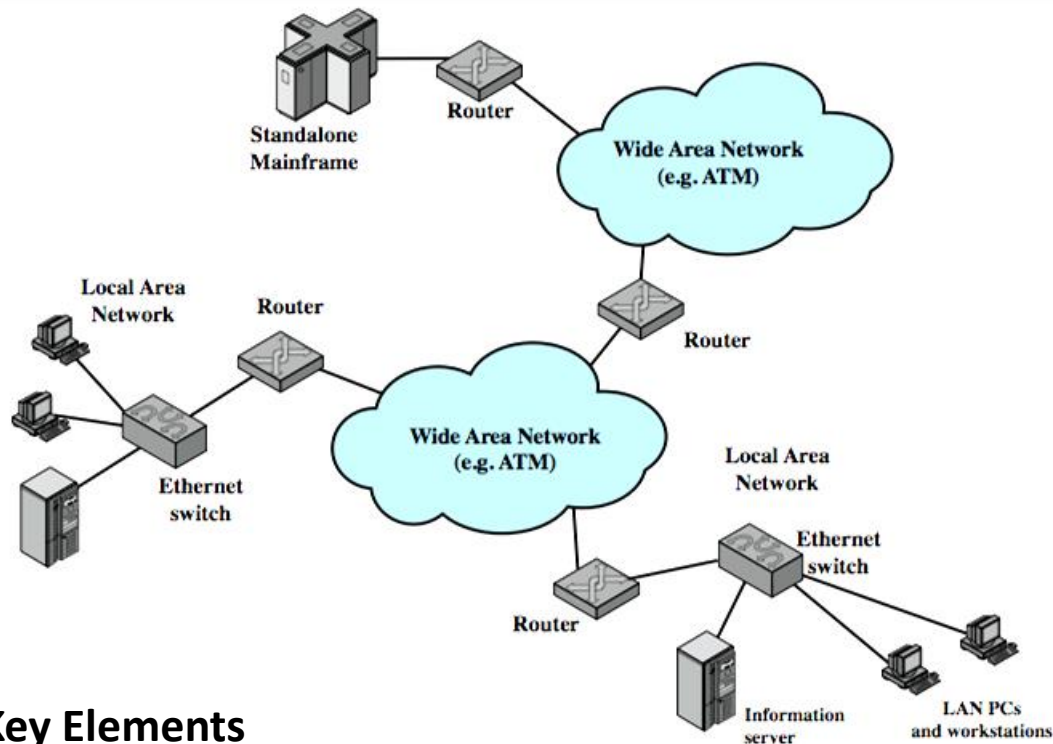

Internet – Key Elements

INTRODUCTION TO LAYERED COMMUNICATION PROTOCOLS



(16)

The Need for Protocol Architecture

- A protocol is a set of rules or conventions that allow peer layers to communicate.
- To transfer data several tasks are performed
 1. The source must activate the communications path or inform network of destination
 2. The source must make sure that destination is prepared to receive data
 3. The file transfer application on the source must confirm file management program at destination is prepared to accept and store the file
 4. A format translation function may need to be performed if the formats on the systems differ



Protocol Architecture Logic

- Logic is divided into subtask modules
 - Implemented separately
- Modules are arranged in a vertical stack
 - Each layer in the stack performs a subset of functions
 - Rely on next layer for more primitive functions
 - Changes in one layer should not require changes in other layers
- The key features of a protocol are:
 - Syntax – format of data blocks
 - Semantics – control information for coordination and error handling
 - Timing – speed matching and sequencing

A simple Protocol Architecture

- Three agents involved
 - Applications (e.g. email, file transfer)
 - Computers
 - Networks
- Application sends data via module(s) to network to another computer which must get it to the intended application

- For more details, refer to:
 - Chapter 1&2, W. Stallings, **Data and Computer Communications**, 8th edition, 2007.
- The lecture is available online at:
 - <http://bu.edu.eg/staff/ahmad.elbanna-courses>
- For inquires, send to:
 - ahmad.elbanna@feng.bu.edu.eg